

ELECTRIC CHAIN HOISTS - STANDARD FEATURES

Standard Features:



Dual Brake System

Disc type motor brake working with a Weston style mechanical load brake provides load lowering control. Electric brake is designed for easy access and simple adjustment.



Upper and Lower Limit Switch

Prevents overwinding by stopping operation in the case of overlifting or overlowering.



Overload Alert

Installed as a load detecting safety device to help prevent overload for greater hoist longevity.



Push Button Control

Compact design to enable one-handed operation. Rated NEMA 4 protection. Mushroom on/off button included. Push button cable has strain relief to prevent cable damage.



Electric Control Panel

Single speed hoists are re-connectable for 208-230-460 power supply. Controls are housed in a NEMA12 enclosure. Control transformer output is 115/1/60. Available in Variable Frequency Drive (VFD) for all motions. VFD is programmed for 2-speed operation. Standard power supply cord is 15 feet.

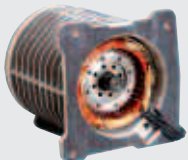

Heavy-Duty Hoist Motor

The hoist motor is a high torque design and is rated 30-minute duty. Class B motor insulation and standard thermal motor protection is included.



Load Sheave / Chain Guide

Full floating chain guide assures proper engagement of chain on load sheave. Features 4 or 5 pockets for better distribution of the load.



Load Chain

Grade 80 load chain is case hardened and has a high resistance to wear and corrosion. All hoists are stocked with 20 feet of lift. Longer lifts are available per requirement. Zinc galvanized load chain is available as an option.



Hooks

Load hook is a forged carbon steel hook with a heavy-duty hook latch. Thrust bearing in hook allows 360° rotation to prevent twisting of load chain. Top hook, for hook suspended hoists, is rigid.



Chain Container

Chain container is standard equipment and is either molded with thick polypropylene material or fabricated from steel to securely contain the chain and chain lubricant. Optional containers are available for long lift applications.

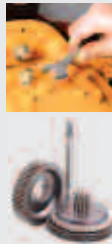

Gear Box / Oil Lubrication

The gearbox utilizes an alloy steel helical and spur gear reduction. Gear inspection and lubrication is easily accessible from the top of the hoist.

Motorized Trolley

Trolley is adjustable for a range of flange widths. Motor includes disc type brake. Side guide rollers are included to promote smooth trolley motion and to minimize wheel and beam wear. Wheels are dual tread design for operation on tapered or flat flange beams. Trolley motor includes class B insulation. Motor is rated 15-minute duty and includes standard thermal motor protection.



ELECTRIC CHAIN HOISTS - HOOK SUSPENSION

Electric Chain Hoists - Single Speed / Hook Suspension:

Cap. (Tons)	Model Number	Std. Lift (ft.)	Push Button Cord Length (ft.)	Lifting Speed (fpm)	Hoist Motor			Load Chain Diameter (in.) X Chain Fall Lines	Add'l 1 ft. of Lift (lbs.)	Net Wt. (lbs.)
					HP	Amp. Draw				
						208V & 230V	460V			
1	2130020	20	18	17	2.4	9.2	4.2	.280 X (1)	0.67	165
1	2130030	20	18	27	2.4	9.2	4.2	.280 X (1)	0.67	165
2	2130040	20	18	13	2.4	9.2	4.2	.280 X (2)	1.34	198
2	2130050	20	18	27	4.7	17	7.9	.441 X (1)	1.81	282
3	2130060	20	18	17	4.7	17	7.9	.374 X (2)	2.69	348
5	2130070	20	18	11	4.7	17	7.9	.441 X (2)	3.63	388
10	2130080	20	18	11	4.7 X (2)	17 X (2)	7.9 X (2)	.441 X (4)	7.26	860

Electric Chain Hoists - Inverter Control / Hook Suspension:

Cap. (Tons)	Model Number	Std. Lift (ft.)	Push Button Cord Length (ft.)	Lifting Speed (fpm)	Hoist Motor			Load Chain Diameter (in.) X Chain Fall Lines	Add'l 1 ft. of Lift (lbs.)	Net Wt. (lbs.)
					HP	Amp. Draw				
						208V & 230V	460V			
1	2130030-VFD-230	20	18	21/7	2.4	9.2	-	.280 X (1)	0.67	170
1	2130030-VFD-460	20	18	21/7	2.4	-	4.2	.280 X (1)	0.67	170
2	2130050-VFD-230	20	18	21/7	4.7	17	-	.441 X (1)	1.81	287
2	2130050-VFD-460	20	18	21/7	4.7	-	7.9	.441 X (1)	1.81	287
3	2130060-VFD-230	20	18	15/5	4.7	17	-	.374 X (2)	2.69	353
3	2130060-VFD-460	20	18	15/5	4.7	-	7.9	.374 X (2)	2.69	353
5	2130070-VFD-230	20	18	11/4	4.7	17	-	.441 X (2)	3.63	393
5	2130070-VFD-460	20	18	11/4	4.7	-	7.9	.441 X (2)	3.63	393



DIMENSIONS - HOOK SUSPENSION HOISTS

1 TO 5 TON HOOK SUSPENSION HOISTS:

Figure A

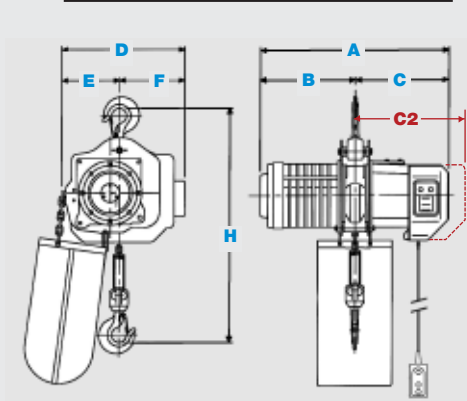
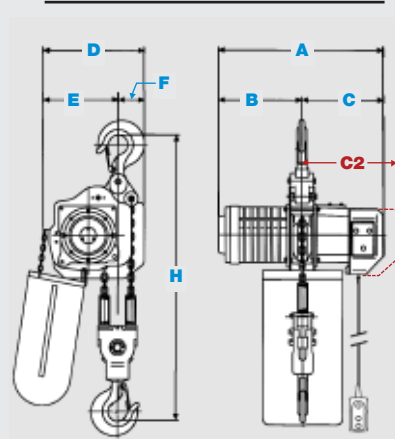

Figure B



Dimensions in Inches (Nominal). *For hook dimensions, see page 8.*

Model Number	A	B	C	C2*	D	E	F	H	Figure
2130020	22.5	11.7	10.8	-	14.2	6.7	7.5	22	A
2130030	22.5	11.7	10.8	12.8	14.2	6.7	7.5	22	A
2130040	22.5	11.7	10.8	-	14.2	8.6	5.6	32	B
2130050	26.1	13.7	12.3	13.5	16.9	7.8	9.1	27	A
2130060	26.1	13.7	12.3	13.5	16.9	10.2	6.7	36	B
2130070	26.1	13.7	12.3	13.5	16.9	10.7	6.2	42	B
2130080	25.3	12.3	13.8	-	39.4	19.7	19.7	51.6	C

* Inverter Control Models only.

10 TON HOOK SUSPENSION HOIST:

Figure C

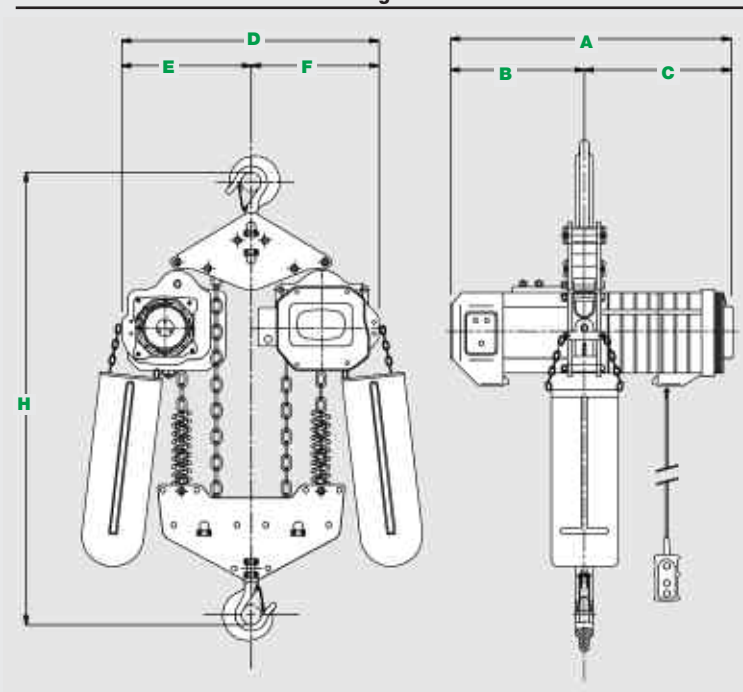

ELECTRIC CHAIN HOISTS - MOTORIZED TROLLEY

Electric Chain Hoists - Single Speed / Motorized Trolley:

Cap. (Tons)	Model Number	Std. Lift (ft.)	Push Button Cord Length (ft.)	Lifting Speed (fpm)	Trolley Speed (fpm)	Hoist Motor			Trolley Motor			Flange Width Adjustability (in.)		Min. Beam Radius (in.)	Load Chain Diameter (in.) X Chain Fall Lines	Add'l 1 ft. of Lift (lbs.)	Net Wt. (lbs.)
						HP	Amp. Draw		HP	Amp. Draw		Standard	Optional				
							208V & 230V	460V		208V & 230V	460V						
1	2130120	20	18	17	36	2.4	9.2	4.2	.54	3.3	1.5	3 to 5.9	5.91 to 12	43	.280 X (1)	0.67	238
1	2130130	20	18	27	36	2.4	9.2	4.2	.54	3.3	1.5	3 to 5.9	5.91 to 12	43	.280 X (1)	0.67	238
2	2130140	20	18	13	36	2.4	9.2	4.2	.54	3.3	1.5	4 to 6.9	6.91 to 12	59	.280 X (2)	1.34	293
2	2130150	20	18	27	36	4.7	17	7.9	.54	3.3	1.5	4 to 6.9	6.91 to 12	59	.441 X (1)	1.81	388
3	2130160	20	18	17	33	4.7	17	7.9	1	5.1	2.2	4 to 6.9	6.91 to 12	59	.374 X (2)	2.69	507
5	2130170	20	18	11	33	4.7	17	7.9	1	5.1	2.2	4 to 7.5	7.51 to 12	79	.441 X (2)	3.63	589
10	2130180	20	18	11	33	4.7 X (2)	17 X (2)	7.9 X (2)	1 X (2)	5.1 X (2)	2.2 X (2)	4 to 7.5	7.51 to 12	N/A	.441 X (4)	7.26	1400

Electric Chain Hoists - Inverter Control / Motorized Trolley:

Cap. (Tons)	Model Number	Std. Lift (ft.)	Push Button Cord Length (ft.)	Lifting Speed (fpm)	Trolley Speed (fpm)	Hoist Motor			Trolley Motor			Flange Width Adjustability (in.)		Min. Beam Radius (in.)	Load Chain Diameter (in.) X Chain Fall Lines	Add'l 1 ft. of Lift (lbs.)	Net Wt. (lbs.)
						HP	Amp. Draw		HP	Amp. Draw		Standard	Optional				
							208V & 230V	460V		208V & 230V	460V						
1	2130130-VFD-230	20	18	21/7	50/17	2.4	9.2	-	.54	3.3	-	3 to 5.9	5.91 to 12	43	.280 X (1)	0.67	248
1	2130130-VFD-460	20	18	21/7	50/17	2.4	-	4.2	.54	-	1.5	3 to 5.9	5.91 to 12	43	.280 X (1)	0.67	248
2	2130150-VFD-230	20	18	21/7	50/17	4.7	17	-	.54	3.3	-	4 to 6.9	6.91 to 12	59	.441 X (1)	1.81	398
2	2130150-VFD-460	20	18	21/7	50/17	4.7	-	7.9	.54	-	1.5	4 to 6.9	6.91 to 12	59	.441 X (1)	1.81	398
3	2130160-VFD-230	20	18	15/5	50/17	4.7	17	-	1	5.1	-	4 to 6.9	6.91 to 12	59	.374 X (2)	2.69	517
3	2130160-VFD-460	20	18	15/5	50/17	4.7	-	7.9	1	-	2.2	4 to 6.9	6.91 to 12	59	.374 X (2)	2.69	517
5	2130170-VFD-230	20	18	11/4	50/17	4.7	17	-	1	5.1	-	4 to 7.5	7.51 to 12	79	.441 X (2)	3.63	599
5	2130170-VFD-460	20	18	11/4	50/17	4.7	-	7.9	1	-	2.2	4 to 7.5	7.51 to 12	79	.441 X (2)	3.63	599



DIMENSIONS - MOTORIZED TROLLEY HOISTS

1 TO 5 TON MOTORIZED TROLLEY HOISTS:

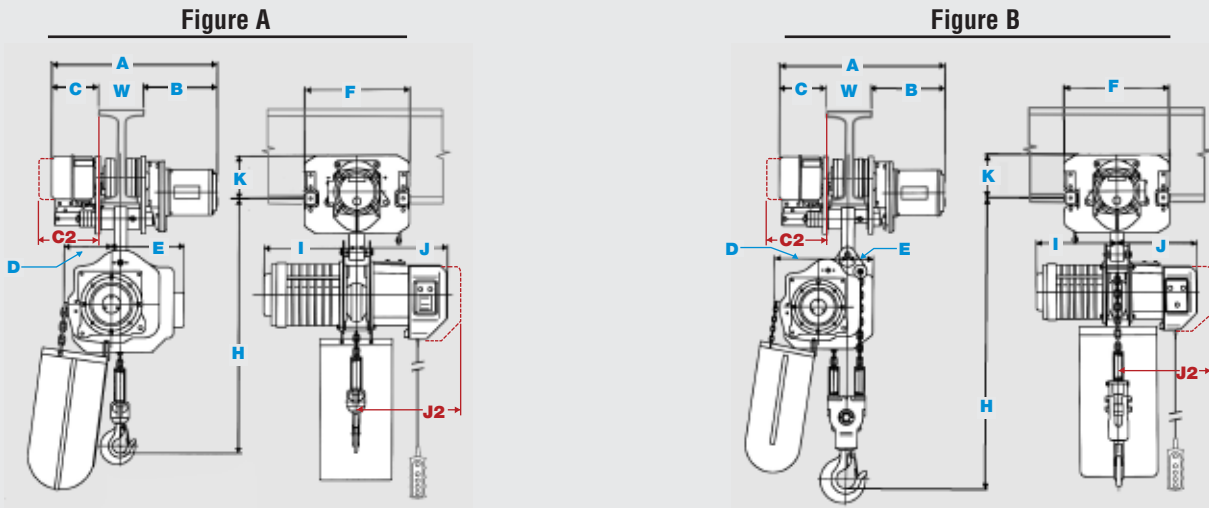

Dimensions in Inches (Nominal). *For hook dimensions, see page 8.*

Model Number	A	B	C	C2*	D	E	F	H	I	J	J2*	K	Figure
2130120	17.5 + W	9.9	7.6	-	6.7	7.5	11.7	23	11.7	10.8	-	5.2	A
2130130	19.5 + W	9.9	7.6	9.6	6.7	7.5	11.7	23	11.7	10.8	12.8	5.2	A
2130140	17.5 + W	9.9	7.6	-	8.6	5.6	12.4	32	11.7	10.8	-	5.2	B
2130150	19.5 + W	9.9	7.6	9.6	7.8	9.1	12.4	27	13.7	12.3	13.5	5.2	A
2130160	20.3 + W	10.7	7.6	9.6	10.2	6.6	14.2	35	13.7	12.3	13.5	5.8	B
2130170	21.6 + W	12.0	7.6	9.6	10.7	5.9	16.1	42	13.7	12.3	13.5	6.1	B

W = Beam width

* Inverter Control Models only.

10 TON MOTORIZED TROLLEY HOIST:

Model Number	A	B	C	D	E	F	H	I	J	K	Figure
2130180	19.6 + W	12.0	7.6	42.13	37.40	24.80	45.67	13.7	12.3	5.70	C

W = Beam width

Figure C

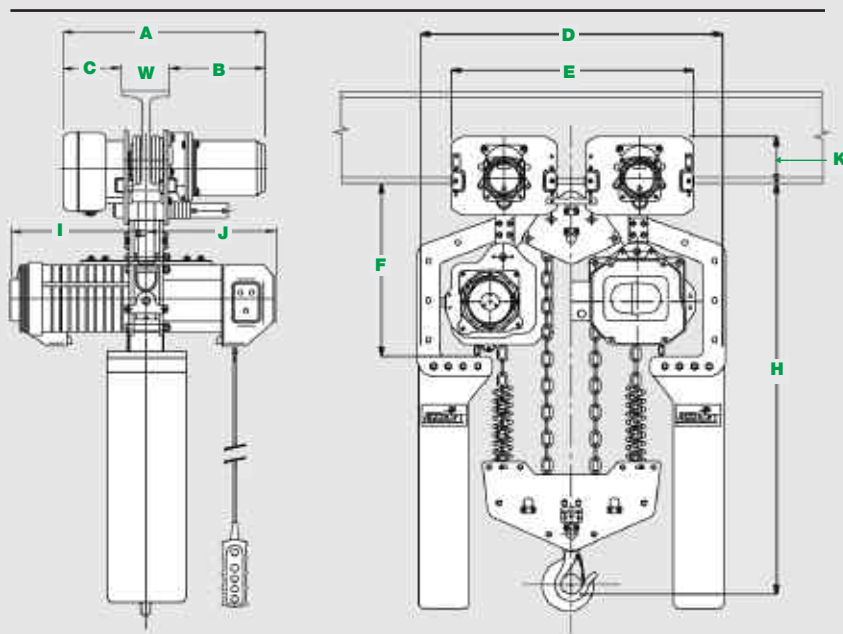

DIMENSIONS - HOOKS AND CHAIN BUCKETS

ELECTRIC CHAIN HOISTS - HOOK DIMENSIONS:

Dimensions in Inches (Nominal)

Capacity	A	B	E	M	N
1 Ton	3.82	0.95	1.28	1.38	1.34
2 Ton	5.73	1.18	1.73	2.11	1.65
3 Ton	6.50	1.38	2.05	2.36	1.73
5 Ton	7.44	1.71	2.44	2.76	2.05
10 Ton	13.45	3.54	4.39	4.72	3.25

HAND CHAIN HOISTS - HOOK DIMENSIONS:

Capacity	A	B	E	M	N
1/2 Ton	2.87	0.62	0.79	1.42	1.22
1 Ton	3.38	0.81	0.94	1.57	1.34
2 Ton	4.45	0.94	1.18	1.97	1.61
3 Ton	5.24	1.10	1.65	2.13	1.77
5 Ton	5.98	1.50	1.81	2.40	1.97
10 Ton	9.29	2.44	3.54	3.27	2.40

LEVER HOISTS - HOOK DIMENSIONS:

Capacity	A	B	E	M	N
3/4 Ton	3.15	0.67	0.87	1.48	1.22
1 1/2 Ton	3.86	0.95	1.10	1.81	1.50
3 Ton	5.24	1.10	1.65	2.13	1.77
6 Ton	5.98	1.50	1.81	2.40	1.97

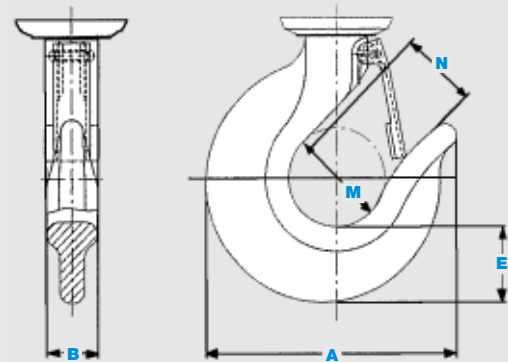

ELECTRIC CHAIN HOISTS - CHAIN BUCKET CAPACITIES:

Model Number	Max. Lift with Stock Bucket (ft.)	Max. Lift With Optional Bucket (ft.)
2130020 2130120	80	130
2130030 2130130	80	130
2130040 2130140	40	65
2130050 2130150	26	58
2130060 2130160	40	60
2130070 2130170	30	45
2130080 2130180	20	48

Steel buckets can be ordered for longer lifts than stated above - please call factory with your application for pricing